

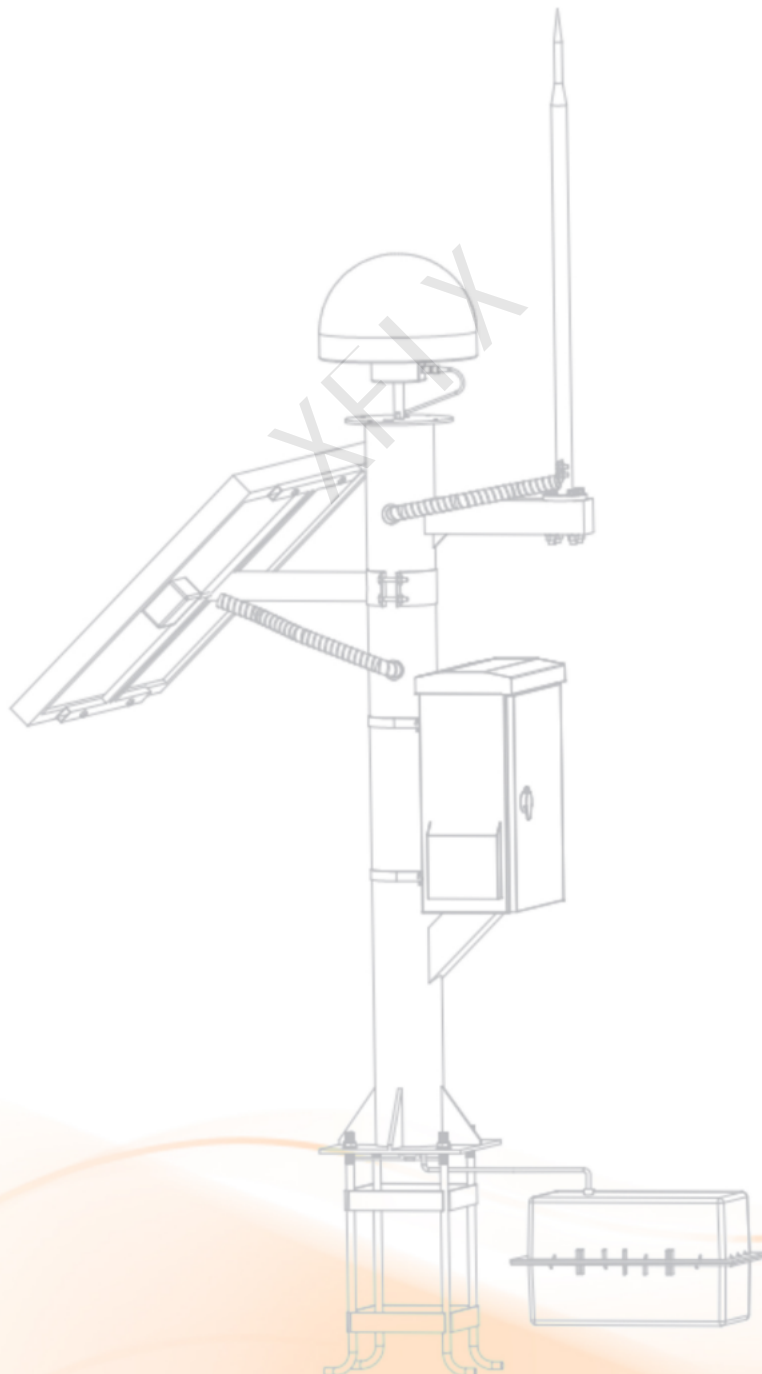

LP3 + Solar Power + Gel Battery



CONTENTS

1.Overall Monitoring Solution Assembly Drawing	1
2.Enclosure Assembly Drawing	2
3. Enclosure Accessories List	3
3. Enclosure Accessories List	4
4.Pole Assembly Accessories List	5
4.Pole Assembly Accessories List	6
5.Mounting Hole Positions and Corresponding Screw Specifications for the Enclosure	7
6.List of Required Installation Tools	8
7.Enclosure Installation Diagram	9
7.Enclosure Installation Diagram	10
7.Enclosure Installation Diagram	11
7.Enclosure Installation Diagram	12
7.Enclosure Installation Diagram	13
7.Enclosure Installation Diagram	14
8.Pole Installation Diagram	15
8.Pole Installation Diagram	16
8.Pole Installation Diagram	17
8.Pole Installation Diagram	18
8.Pole Installation Diagram	19



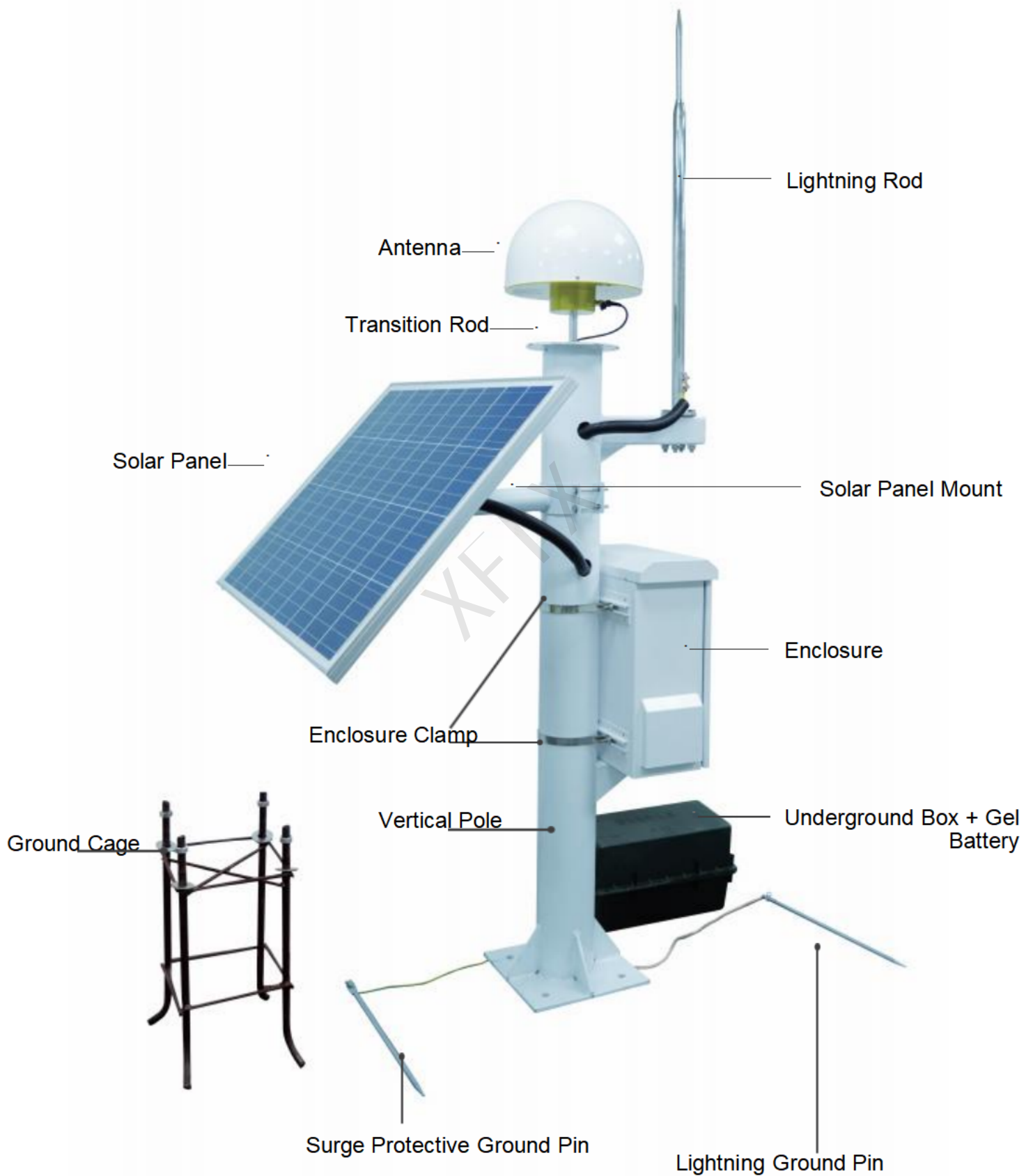



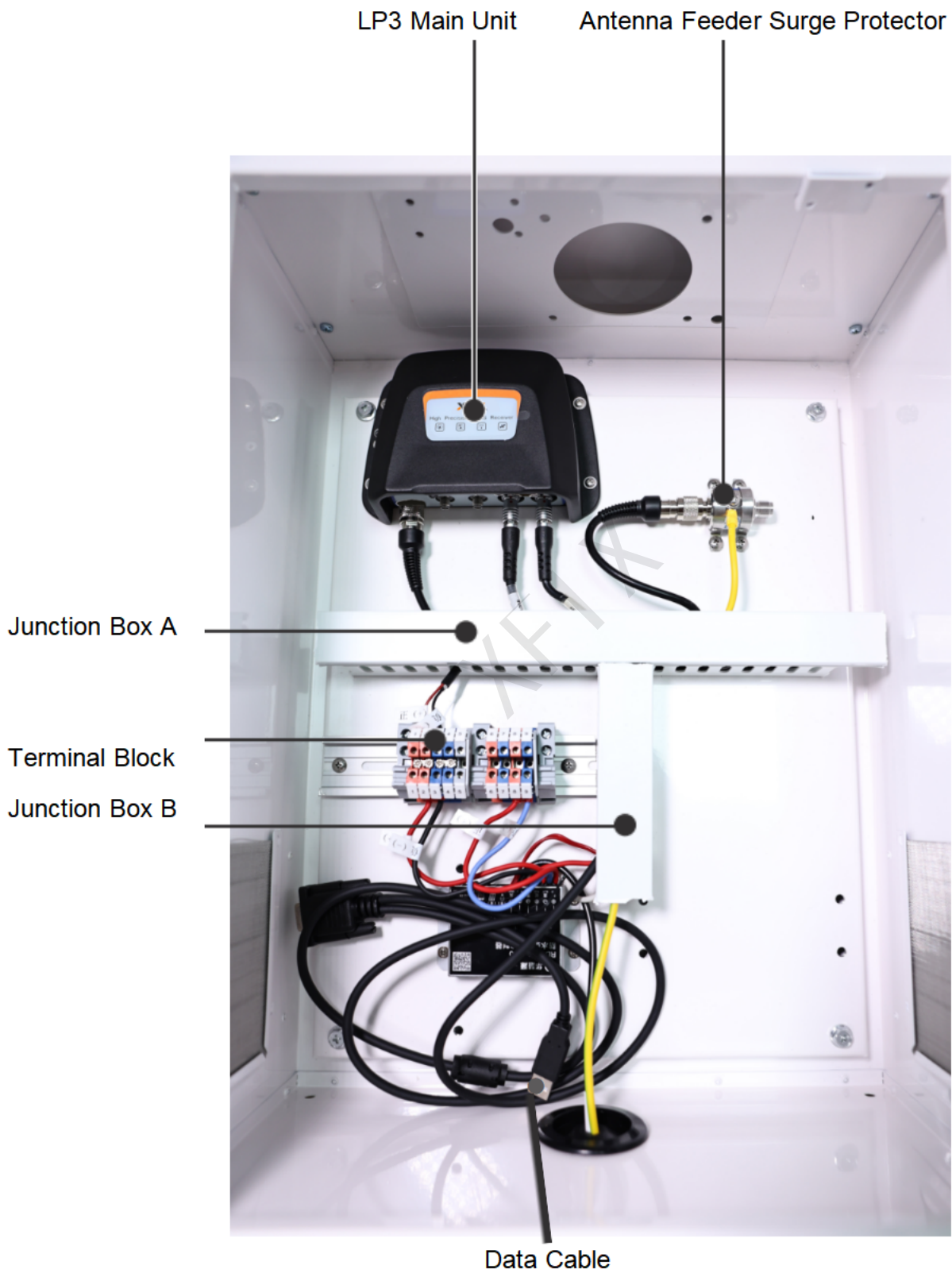









1. Overall Monitoring Solution Assembly Drawing









2.Enclosure Assembly Drawing

















3. Enclosure Accessories List

NO.	Item	Specification	QTY	Image
1	UPS Enclosure	White	1	
2	UPS Enclosure Base Plate	White	1	
3	Phillips Large Flat Head Screw (TM Type)	SS304, Natural Finish, M5×8	4	
	Standard Spring Washer	SS304, Natural Finish, M5	4	
4	PL3L (Single Antenna)	/	1	
5	Phillips Large Flat Head Screw (TM Type)	SS304, Natural Finish, M4×8	13	
	Standard Spring Washer	SS304, Natural Finish, M4	6	
6	Antenna Feed Surge Protector	SS304, Natural Finish	1	
7	UPS Surge Protector Bracket	SS304, Natural Finish	2	
8	UPS Junction Box A	PVC, Gray-White, 40×30×300mm	1	
9	UPS Junction Box B	PVC, Gray-White, 40×30×110mm	1	
10	Internal Phillips External Hex Locking Screw	SS304, Natural Finish, M6×8	4	
11	Solar Charge Controller	RD1224-H10	1	
12	Phillips Pan Head Screw with Washer	Carbon Steel, Silver-White, Nickel-Plated, M3×8	5	
13	C45 DIN Rail (U-Type)	1.3mm Thickness, Oxidized Round Holes, Hole Pitch 17mm, Length 144.5mm	1	
14	Terminal Block Partition	UK-2.5B, Gray	2	





3. Enclosure Accessories List

NO.	Item	Specification	QTY	Image
15	Terminal Block (Orange-Red)	UK-2.5B, Nylon, Orange-Red	4	
	Terminal Block (Gray)	UK-2.5B, Nylon, Gray	1	
	Terminal Block (Blue)	UK-2.5B, Nylon, Blue	4	
16	Marker Strip (Numeric)	UK Series, White, 10 pcs/strip, 1 2 3 4 5 6 7 8 9 10	2	
17	Terminal Block Jumper FBI-2-6	FBI-2-6, Silver, with Phillips Screw	2	
18	Terminal Block BUK End Stopper	UK-2.5B, Gray	3	
19	Crimp Terminal E1508	Red, 1.5mm ²	12	
20	TNC Male-to-Female Adapter Cable	Length: 0.4m	1	
21	Corrugated Pipe	d25, PP Black, Slit, 1m	1	
22	O-Type Crimp Insulated Terminal	RV5.5-8, Black	3	
23	Wire Marker Sleeve	White Heat Shrink Tube, Marking: + -	4	
24	4mm ² Multi-Strand Electronic Wire	Yellow-Green, 5m	1	
25	2PIN Molex Power Cable	0.5m	1	
26	Data Cable	/	1	
27	TNC Antenna Cable	5m	1	
28	1.5mm ² 2-Core PVC Wire (UPS Gel Battery Power Cable)	Black Jacket, Red/Black Core Wires, 3m	1	

4.Pole Assembly Accessories List

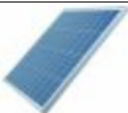
NO.	Item	Specification	QTY	Image
1	UPS Top Lightning Rod	Stainless Steel, 1m, D32, H1000	1	
2	Hex Lock Nut	SS304 Natural Finish, M12	4	
	Hex Bolt	SS304 Natural Finish, M12×100	4	
3	UPS Pole	Hot-Dip Galvanized, White, 1.5m	1	
4	UPS Enclosure	Galvanized, White, V4520-V1	1	
5	Lightning Rod Ground Wire	5m, 16mm ²	1	
6	UPS Grounding Pin	0.5m, Galvanized	2	
7	Gel Battery	Capacity 100Ah, with Screws (M8×20)	1	
8	Gel Battery Underground Box	Black, Internal Dimensions 415×195×260mm	1	
9	Ground Cage	Steel, supplied with M16 Nuts and Washers	1	
10	Multi-Strand Electronic Wire	4mm ² , Yellow-Green, 5m, pre-wired inside enclosure	1	
11	U-Bolt Clamp	SS304, Hole Ø8.5, Length 140mm	2	
	T-Bolt	SS304, M8×25	4	
	Hex Lock Nut	SS304, M8	4	
	Washer	SUS304, Size: M8×17×1.5	4	
12	Corrugated Pipe	d25, PP Black, slit, 1m	2	

4.Pole Assembly Accessories List

NO.	Item	Specification	QTY	Image
13	Solar Panel Bracket	Hot-Dip Galvanized, White, with Bolts and Nuts (M8×90)	1	
14	Solar Panel	100W, with Screws (M5×20)	1	
15	Antenna Centering Rod Adapter	Both Ends Thread 5/8-11UNC-2A, Length 98mm, Aluminum 6061 Natural Finish	1	
16	TNC Antenna Cable	5m, pre-wired inside enclosure	1	
17	Choke Ring Antenna	White	1	

XFLIX

5. Mounting Hole Positions and Corresponding Screw Specifications for the Enclosure

A - 4pcs M6×8 Internal Phillips External Hex Locking Screws
For fixing the base plate

B - 4pcs M5×8 Phillips TM Large Flat Head Screws + Washers
For fixing the PL3L main unit

C - 4pcs M4×8 Phillips TM Large Flat Head Screws + Washers
For fixing the antenna feed surge protector

D - 7pcs M4×8 Phillips TM Large Flat Head Screws + Washers
For fixing the junction boxes

E - 2pcs M4×8 Phillips TM Large Flat Head Screws + Washers
For fixing the terminal block DIN rail





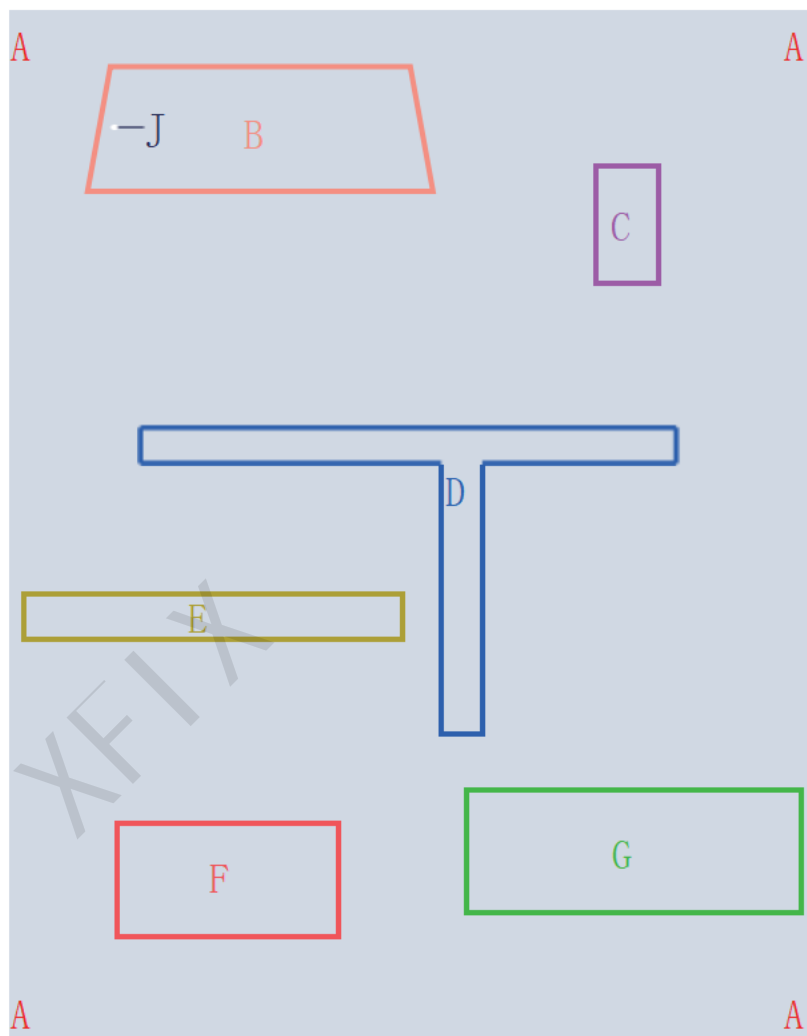

F - 4pcs M3×8 Phillips Pan Head Screws with Washer
For fixing the solar charge controller

G - 4pcs M6×8 Internal Phillips External Hex Locking Screws
For fixing the UPS power supply

J - 1pc M3×8 Phillips Pan Head Screw with Washer
For grounding the PL3L main unit

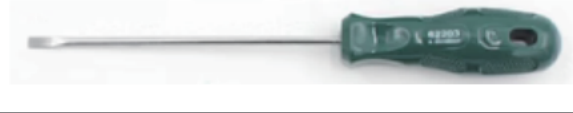

6.List of Required Installation Tools

Installation Tools		
Specification	Corresponding Screws & Terminals	Image
Phillips #0 Screwdriver	M3×8, M4×8, jumper bar screws	
Phillips #1 Screwdriver	M5×8	
Hex Socket Φ11 Screwdriver	M6×8	
Flat #0 Screwdriver	Terminal block screws	
0.25–2.5mm ² Ferrule Crimping Tool	Antenna feed surge protector ground wire	
0–25mm Adjustable Wrench	Antenna connector, lightning rod hex screws, enclosure clamps	
0.25–6mm ² Tubular Terminal Crimping Tool	All crimp terminals	

7. Enclosure Installation Diagram

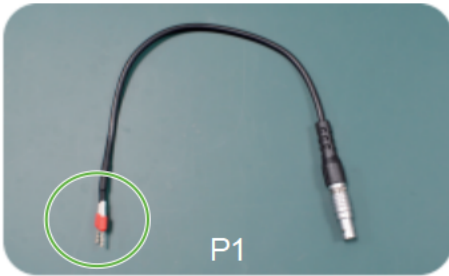

1. Modified PW power cable

As shown in Figure 1, slide the “+ / -” wire markers onto the red (+) and black (-) wires respectively. Attach the red E1508 crimp terminal and crimp firmly with a crimping tool.

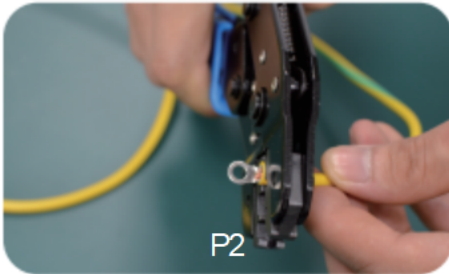

2. Modified surge protector ground wire

As shown in Figure 2, remove the original cable lug from the surge protector. Cut a 4mm² yellow-green wire to 5 meters in length, strip 8mm of insulation from both ends. Attach the original lug to one end and an RV5.5-8 lug to the other, then crimp both firmly with a crimping tool.



3. Modified gel battery power cable

As shown in Figure 3, strip the 1.5mm² gel battery power cable. Slide on the wire markers: red (+) and black (-). Attach the red E1508 crimp terminal and crimp firmly with a crimping tool.

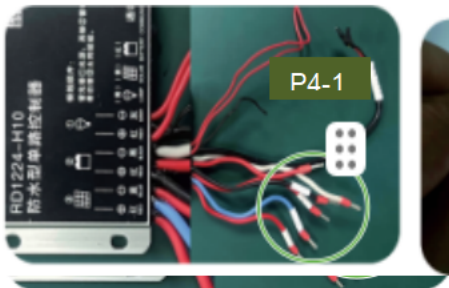

4. Modify the solar charge controller

As shown in Figure 4-1, mark the wires as red (+), blue (-), black (-), gray (-), install red E1508 crimp terminals and crimp tightly. As shown in Figure 4-2, wrap the 3-core red, black and yellow wires with electrical tape to avoid exposed ends.



5. Cut the terminal block DIN rail

Cut the C45 U-type DIN rail into 144.5mm lengths as shown in Figure 5.

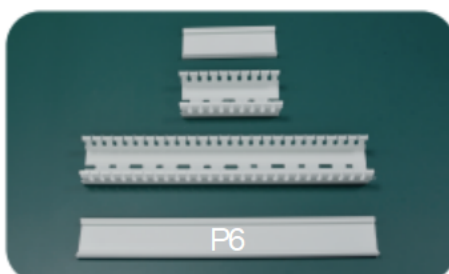

6. Cut the junction boxes

As shown in Figure 6, cut the UPS junction box A into 300mm lengths, and UPS junction box B into 110mm lengths.

7. Enclosure Installation Diagram

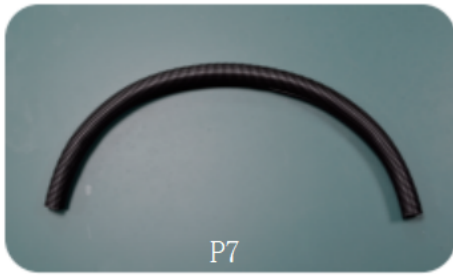

7. Corrugated pipe
Cut the d25 corrugated pipe into 1-meter sections as shown in Figure 7.

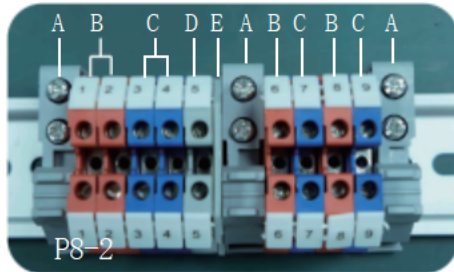
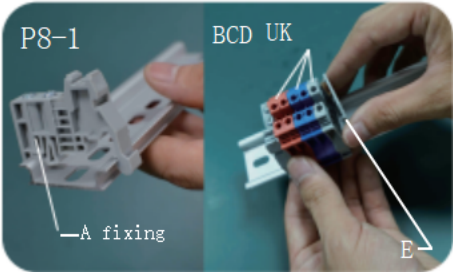

8. Install the terminal block
As shown in Figure 8-1, attach the fixing brackets, UK terminals and terminal partitions. Press the terminal partitions firmly onto the terminals. Quantity: A-3, B-4, C-4, D-1, E-1 as shown in Figure 8-2.

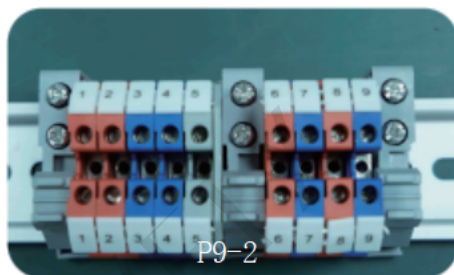
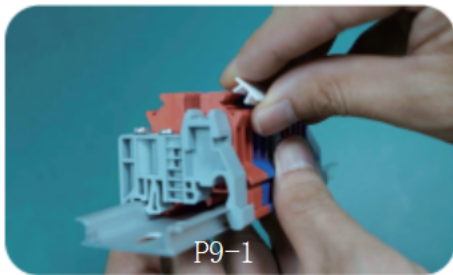

9. Install marker strips
Install the markers into the terminal strip as shown in Figure 9-1. From left to right: 1, 2, 3, 4, 5, 6, 7, 8, 9, as shown in Figure 9-2.

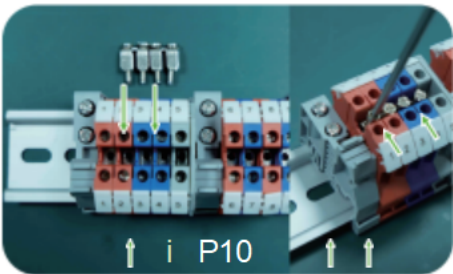

10. Install connecting strips
As shown in Figure 10, insert two sets of FBI-2-6 connecting strips into the fixing holes of terminals 1-2 and 3-4 respectively, then tighten the 4 fixing screws.

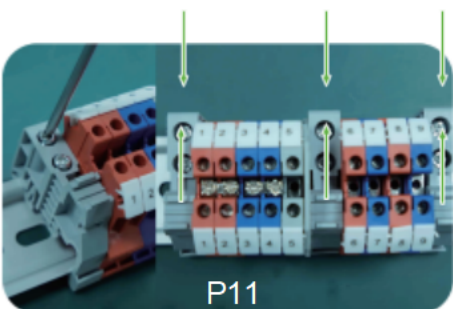

11. Tighten the fixing parts
As shown in Figure 11, press all UK-2.5B terminal blocks firmly by hand, then use a screwdriver to tighten the 6 screws on the EUK fixing parts to ensure no gaps between the terminal blocks.

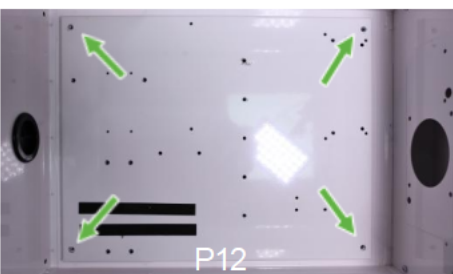

12. Remove the base plate from the enclosure
As shown in Figure 12, remove the 4 internal Phillips external hex locking screws, then take out the base plate from the enclosure.

7. Enclosure Installation Diagram

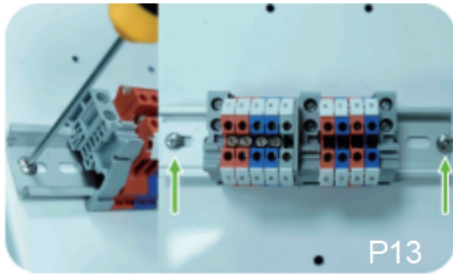

13. Secure the terminal block to the base plate
As shown in Figure 13, place the terminal block at the corresponding position on the base plate according to the enclosure assembly drawing. Tighten with 2 M4 Phillips screws fitted with M4 spring washers.

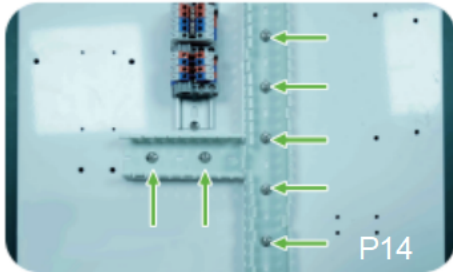

14. Install connecting strips
According to the enclosure assembly drawing (Page P02), fasten Junction Box A and Junction Box B to the corresponding positions on the base plate with M4 Phillips screws respectively, as shown in Figure 14.

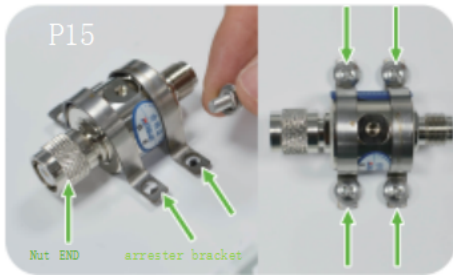

15. Secure the antenna feeder surge protector
According to the enclosure assembly drawing (Page P02), install the surge protector at the corresponding position on the base plate with the nut side facing the PL3L unit. Fit the two surge protector brackets, then tighten with 4 M4 Phillips screws equipped with spring washers, as shown in Figure 15.



16. Secure the PL3L main unit
Install the unit on the base plate per the assembly drawing (Page P02), fasten with 4 M5 Phillips screws with spring washers as shown in Figure 16-1. Fit an M3x8 grounding screw into the unit's grounding hole as shown in Figure 16-2.

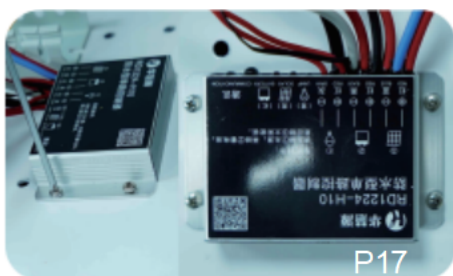

17. Secure the solar charge controller
According to the enclosure assembly drawing (Page P02), place the solar charge controller at the corresponding position on the base plate and fix it with 4 M3x8 Phillips pan head screws with washers, as shown in Figure 17.

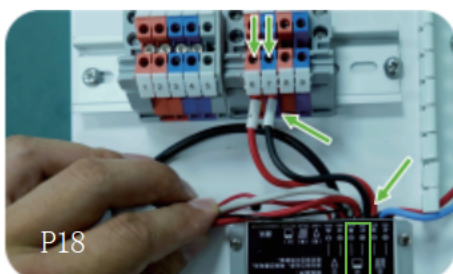

18. Secure the solar charge controller
According to the enclosure assembly drawing (Page P02), place the solar charge controller at the corresponding position on the base plate and fix it with 4 M3x8 Phillips pan head screws with washers, as shown in Figure 17.

7. Enclosure Installation Diagram

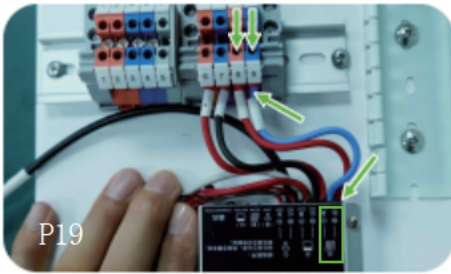

19. Solar controller solar panel wiring
As shown in Figure 19, connect the red and blue solar wires to terminals 8 (red) and 9 (blue) on the terminal block, then tighten the terminal screws.

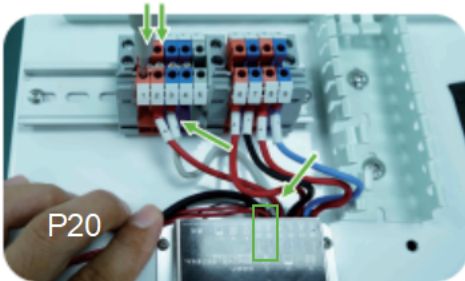

20. Solar controller power supply wiring
As shown in Figure 20, connect the red and gray power wires to terminals 2 (red) and 3 (gray) on the terminal block, then tighten the terminal screws.

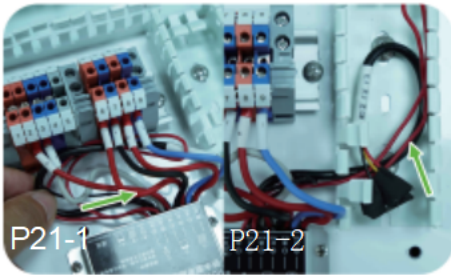

21. Cable management for solar charge controller
Route the unused wire harnesses into Junction Box B as shown in Figure 21-1; the result is shown in Figure 21-2.

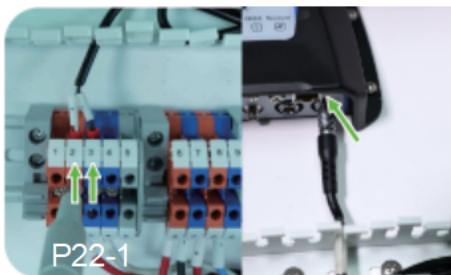

22. Wiring for Lemo plug power cable
As shown in Figure 22-1, insert the 2-pin Lemo plug power cable into the "PW" port of the PL3L with the red dots aligned.

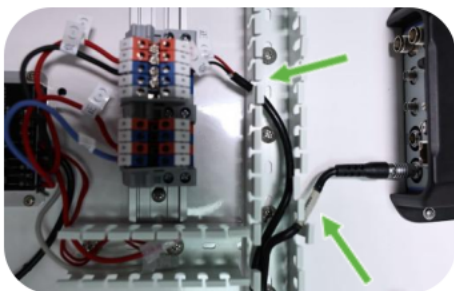

Connect the other end to terminals 2 (+) and 3 (-) on the terminal block and tighten. Route the cable through Junction Box A as shown in Figure 22-2.



7. Enclosure Installation Diagram

23. Ground wire connection

As shown in Figure 23-1, connect one end to the "GNSS" port of the PL3L, and the other end to the nut side of the surge protector as shown in Figure 23-2. Route the wire in Junction Box A as shown in Figure 23-3.



24. Install the base plate

As shown in Figure 24-1, tilt and install the assembled base plate into the enclosure, then tighten the 4 M6 external hex locking screws as shown in Figure 24-2.



25. Data cable connection
As shown in Figure 25-1, insert the Lemo connector of the data cable into the "DATA" port of the PL3L with red dots aligned, and route the cable as shown in Figure 25-2



26. Install enclosure rubber boot and feed through ground wire & gel battery power cable

Cut the rubber boot with scissors as shown in Figure 26-1. Feed the ground wire of the antenna feeder surge protector and the gel battery power cable into the enclosure through the rubber boot as shown in Figure 26-2. Insert the cables into the corrugated pipe and install the pipe into the rubber boot as shown in Figure 26-3.

7. Enclosure Installation Diagram



27. Ground wire connection for antenna feeder surge protector

As shown in Figure 27-1, route the ground wire from the enclosure cable hole through Junction Box B and out of Junction Box A. Place the lug under the top screw of the surge protector and secure the ground wire as shown in Figure 27-2.

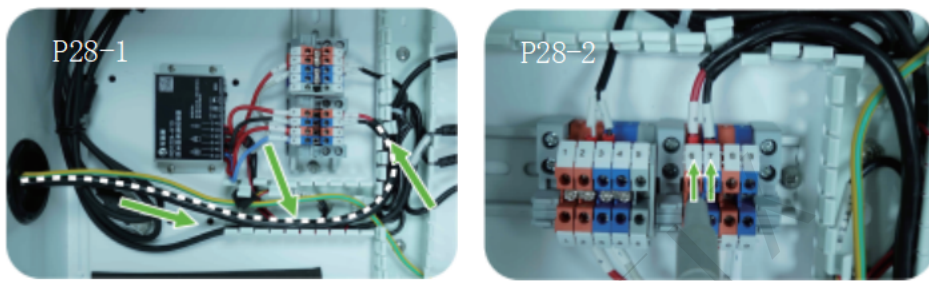

28. Gel battery power cable connection

As shown in Figure 28-1, route the gel battery power cable from the enclosure cable hole through Junction Box B and out of Junction Box A. Connect the red (+) and black (-) wires to terminals 6 (red) and 7 (black) on the terminal block and tighten, as shown in Figure 28-2.



29. Install junction box covers

Install the covers for Junction Box A and B respectively as shown in Figure 29.

8. Pole Installation Diagram

Lightning Rod Ground Wire
Feedthrough Hole

Solar Panel Power Cable
Feedthrough Hole

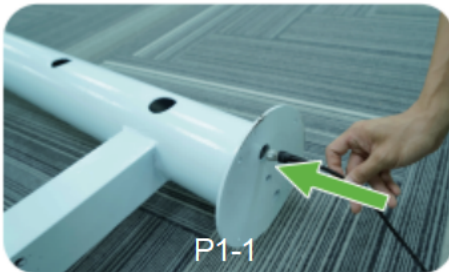
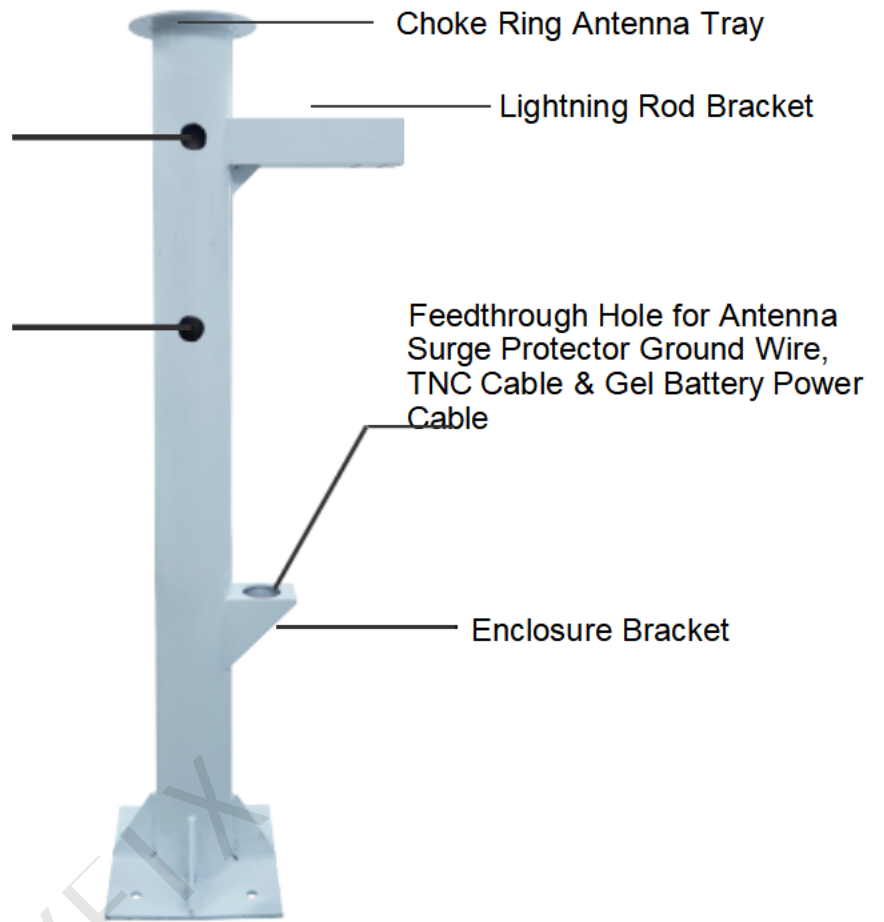

1. TNC cable feedthrough
Route the TNC cable down through the choke ring antenna tray at the pole top (easier with the pole upright), then out through the enclosure bracket hole as shown in Figures 1-1 & 2.

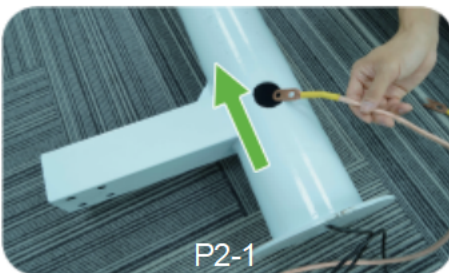

2. Feed lightning rod ground wire
Pass it down through the ground wire hole (easier with pole upright) and out the pole bottom as shown.

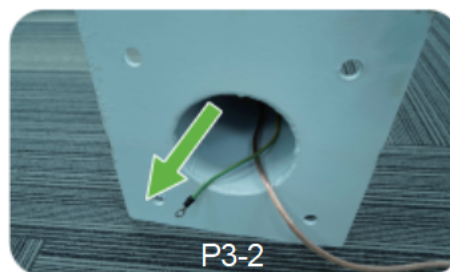

3. Feed the surge protector ground wire
Pass it down through the enclosure bracket hole and out from the pole bottom as shown.

8.Pole Installation Diagram

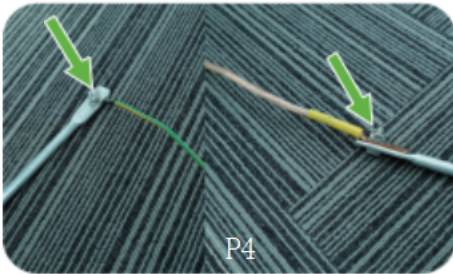

4. Ground rod connection

Secure the surge protector ground wire and lightning rod ground wire to the two ground rods with the supplied screws as shown in Figure 4.

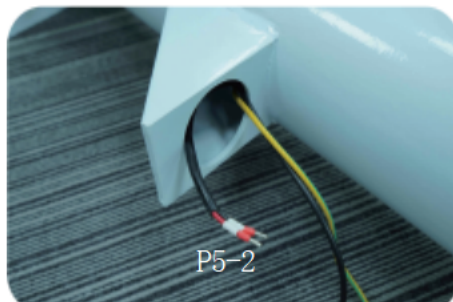
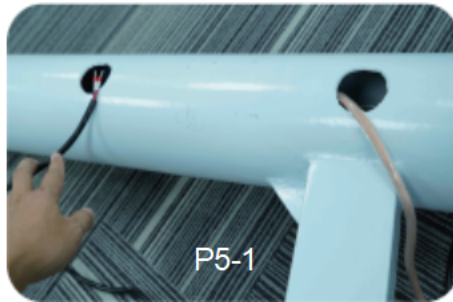

5. Feed solar panel power cable

Pass it down through the cable hole and out from the enclosure bracket as shown.

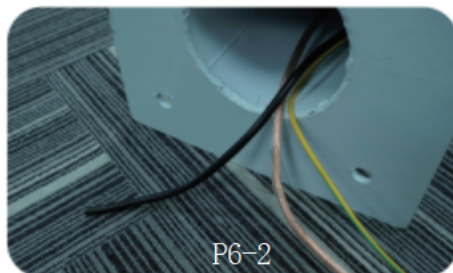
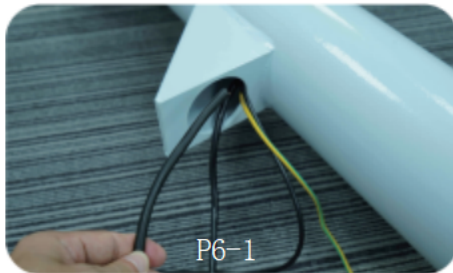

6. Thread the gel battery power cable

Route the power cable downward through the hole in the chassis bracket and out through the bottom of the pole as shown in Figure 6-1 and Figure 6-2.

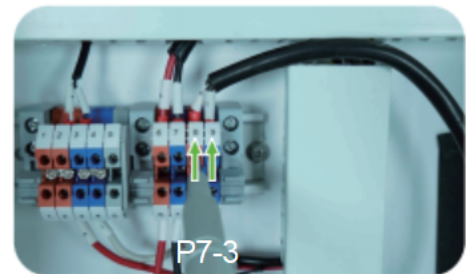
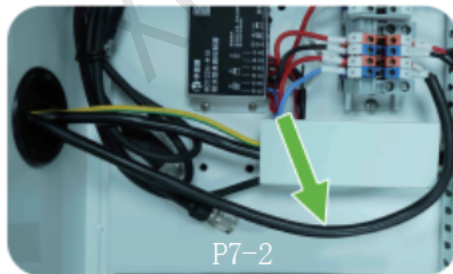

7. Connect the solar panel power cable

Route the TNC cable and solar panel power cable into the enclosure through the cable hole at the bottom of the enclosure as shown in Figure 7-1 and Figure 7-2. Connect the red (+) terminal and black (-) terminal of the solar panel power cable to terminals 8 (red) and 9 (black) on the terminal block, then tighten the screws as shown in Figure 7-3.

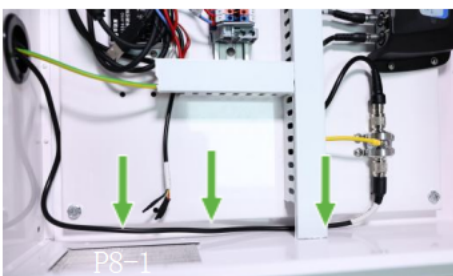

8. Connect the TNC cable

Route the TNC cable as shown in Figure 8-1, then connect it to the antenna surge protector as shown in Figure 8-2.

8. Pole Installation Diagram

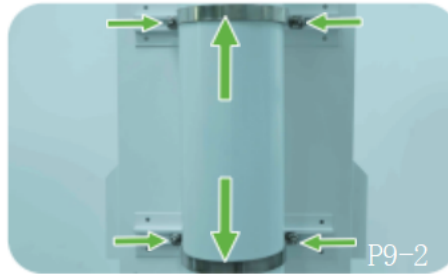

9. Secure the enclosure
Place the enclosure onto the pole's enclosure bracket first. As shown in Figure 9-1, insert 4 M8 T-bolts with washers into the enclosure's slots. Align the clamp with the 4 T-bolts (Figure 9-2), then tighten the M8 lock nuts to secure the enclosure to the pole.



10. Secure the lightning rod
Fasten the lightning rod to the pole arm with 4 M12 screws as shown in Figure 10.

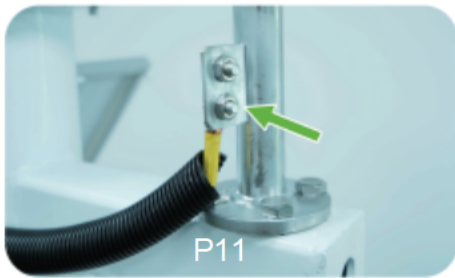

11. Secure the soft copper wire
Fasten the lug of the soft copper wire to the lightning rod's terminal using the two included screws, then cover the wire with a corrugated pipe as shown in Figure 11.



12. Secure the solar panel to the bracket
Mount the solar panel to the bracket using the 4 included M5x20 screws as shown in Figure 12.

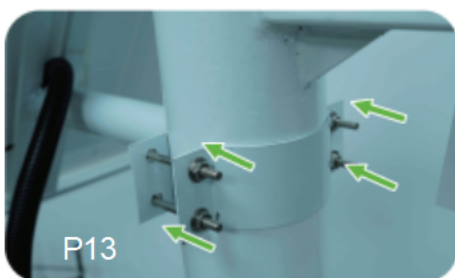

13. Secure the solar panel bracket to the pole
Fasten the solar panel bracket to the pole using the 4 included M8x90 screws as shown in Figure 13.



14. Route the solar panel power cable into the corrugated pipe
Cover the exposed solar panel power cable with a corrugated pipe and feed it into the pole as shown in the figure.

8. Pole Installation Diagram

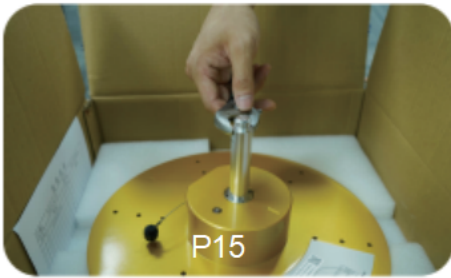

15. Connect the choke ring antenna adapter rod
Screw the adapter rod clockwise into the antenna base as shown in Figure 15, then tighten it with a wrench.

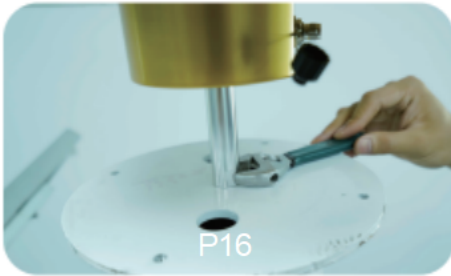

16. Secure the antenna to the pole
Align the adapter rod with the threaded hole on the pole, mount the antenna onto the pole clockwise and tighten it with a wrench as shown in Figure 16.

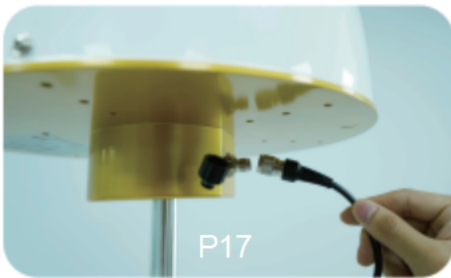

17. Connect the TNC cable
Insert the male end of the TNC cable into the TNC female port of the antenna as shown in Figure 17, and tighten the nut on the male end clockwise to secure it.



18. Secure the pole
Erect the pole and align it with the anchor bolts, then fix the pole with nuts as shown in Figure 18. (Finally, seal the cable holes on the pole with foam sealant to prevent foreign objects from entering.)

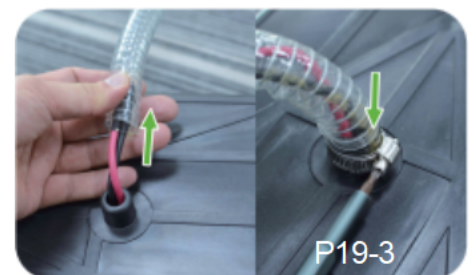

19. Gel battery cable feedthrough

Place the gel battery into the lower half of the underground enclosure as shown in Figure 19-1. Use a screwdriver to pierce the pre-cut cable hole on the enclosure's top cover (Figure 19-2). Tape the terminals of the gel battery power cable, then feed the cable out through the hole from inside the cover. Route the cable through the hose provided with the enclosure, then insert one end of the hose into the cable hole and secure it with a hose clamp as shown in Figure 19-3.

8.Pole Installation Diagram

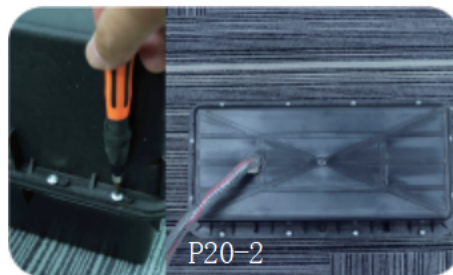
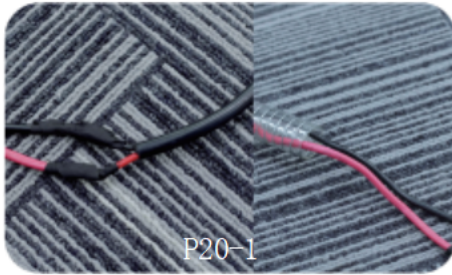

20. Bury the gel battery

As shown in Figure 20-1, connect the gel battery power cable to the pole power cable: red (+) to red (+), black (-) to black (-). (Seal the hose outlet with foam sealant to prevent water and debris from entering.) As shown in Figure 20-2, close the cover and secure the upper and lower parts of the underground box with the 12 self-tapping screws provided. Finally, place the box into the pre-dug pit and backfill it.

XFLIX