

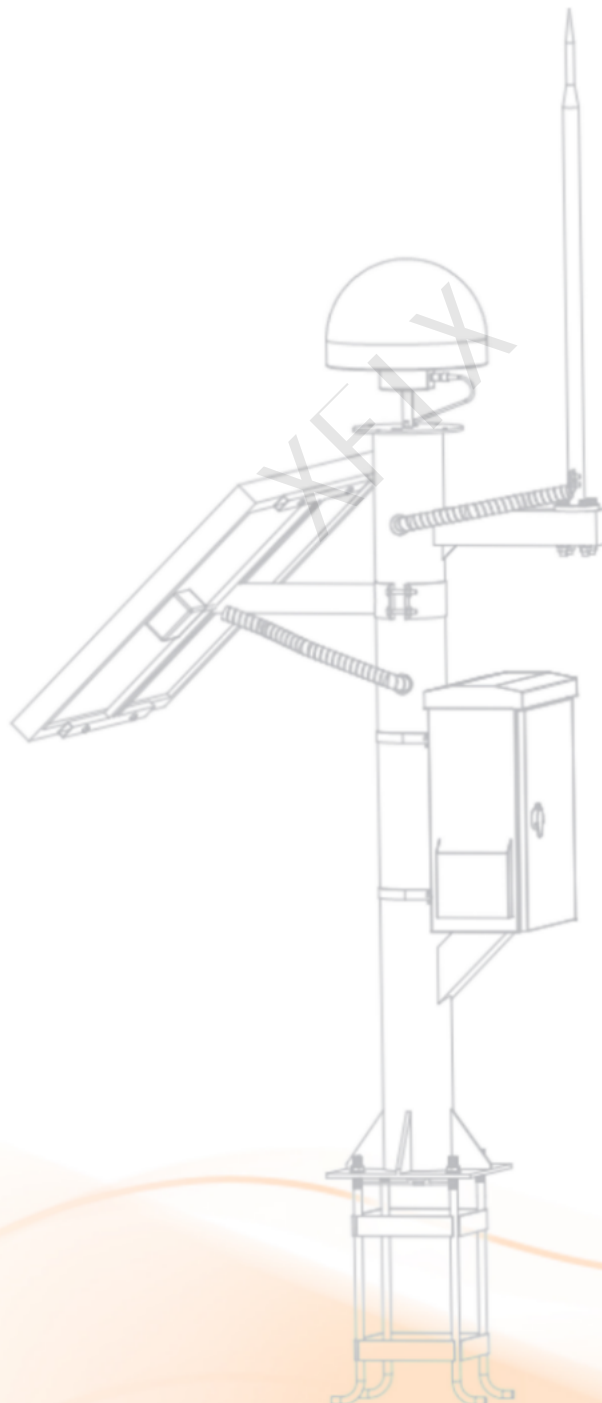

LP3 + Solar Power + UPS



CONTENTS

I. General Assembly Diagram of Monitoring Solution.....	1
I. General Assembly Diagram of Monitoring Solution.....	2
III. Enclosure Accessories List.....	3
III. Enclosure Accessories List.....	4
III. Enclosure Accessories List.....	5
IV. Pole Assembly Components List.....	6
V. Enclosure Mounting Hole Layout and Corresponding Screw Specifications.....	8
VI. Installation Tools List.....	9
VII. Enclosure Installation Diagram.....	10
VII. Enclosure Installation Diagram.....	11
VII. Enclosure Installation Diagram.....	12
VII. Enclosure Installation Diagram.....	13
VII. Enclosure Installation Diagram.....	14
VII. Enclosure Installation Diagram.....	15
VII. Enclosure Installation Diagram.....	16
VIII. Pole Installation Diagram.....	17

XFLIX

I. General Assembly Diagram of Monitoring Solution

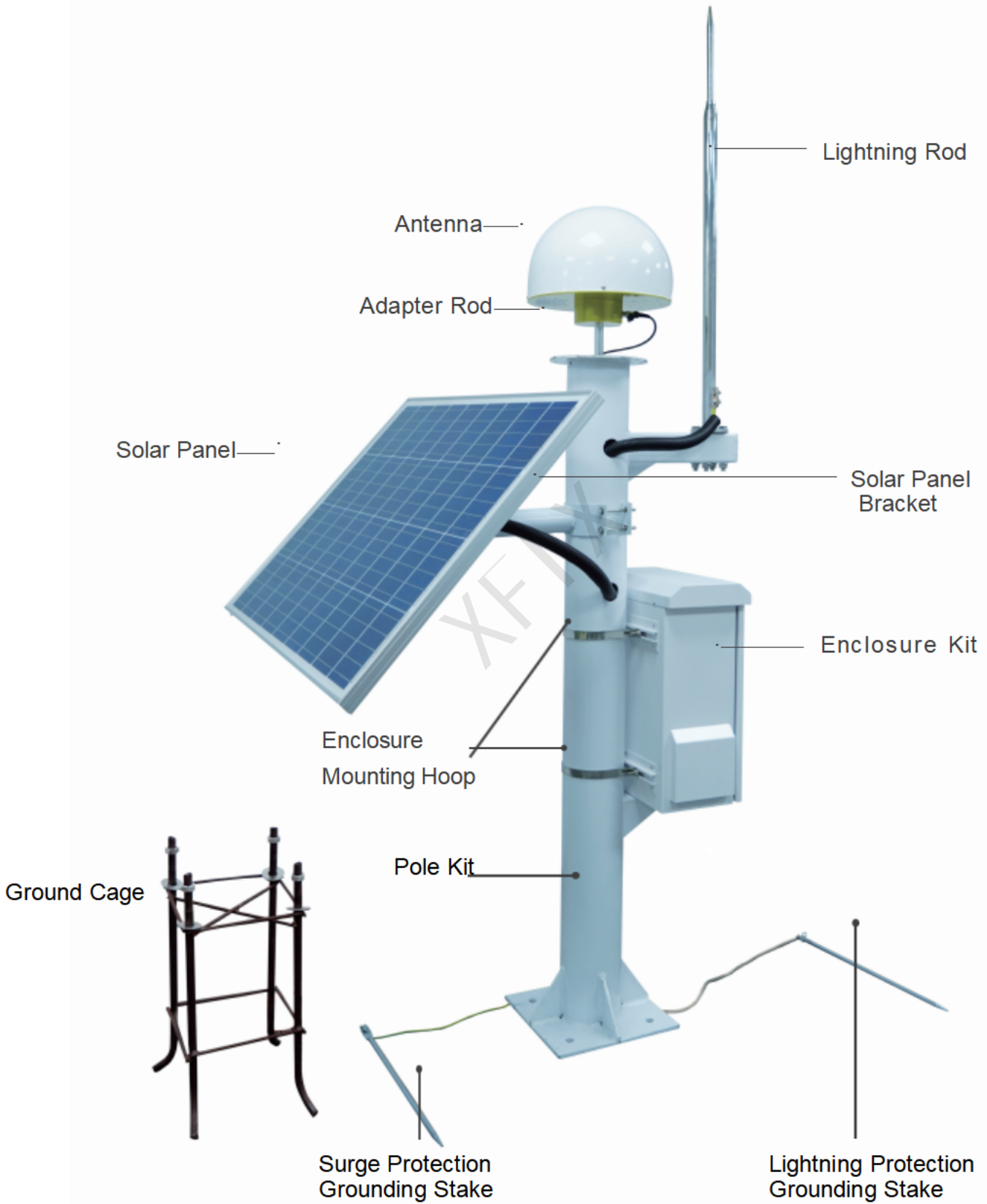



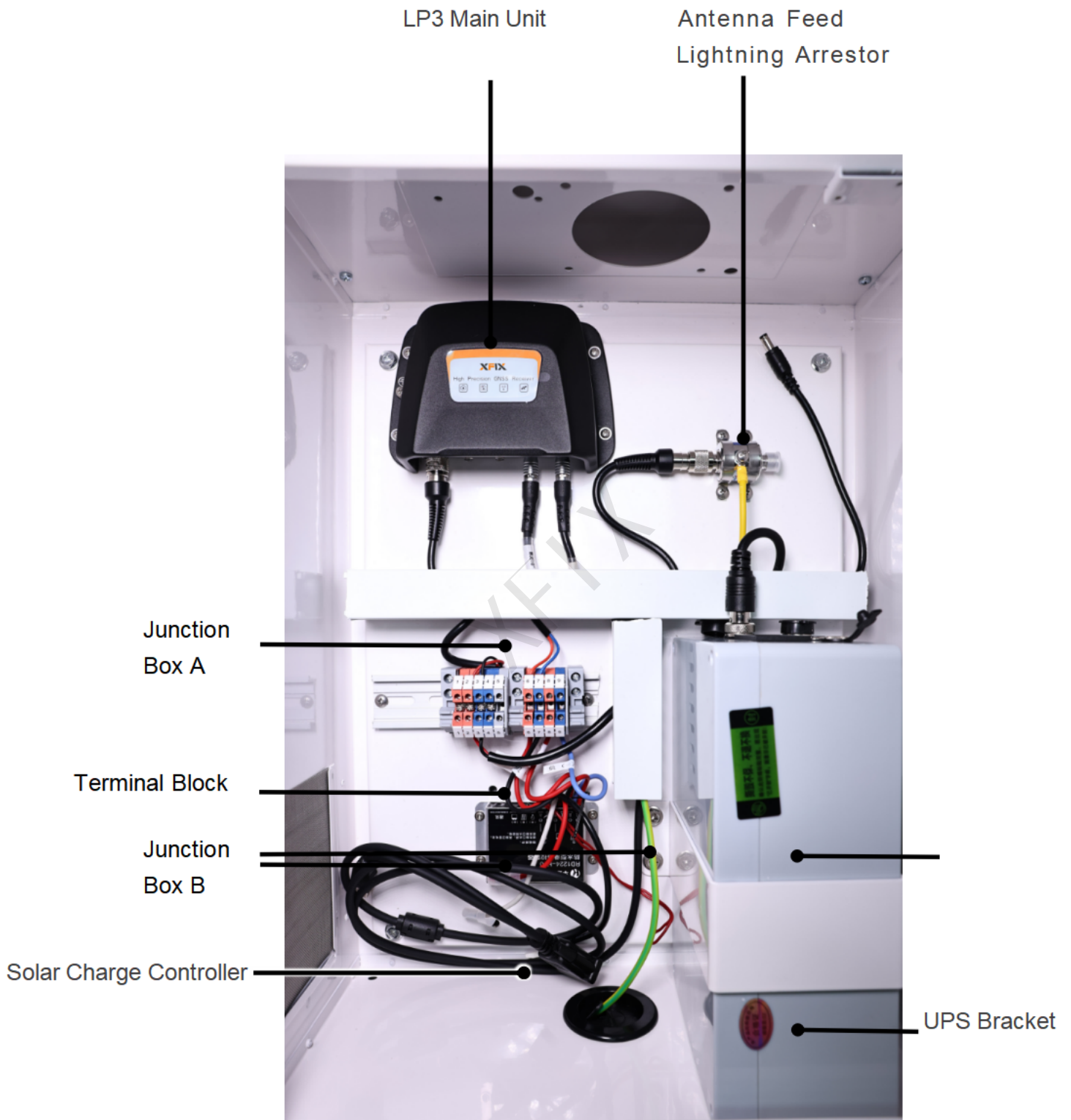













I. General Assembly Diagram of Monitoring Solution



















Data Cable



III. Enclosure Accessories List

NO	Full Material Name	Specification	Unit	Image
1	UPS Enclosure	White	1	
2	UPS Enclosure Bottom Plate	White	1	
3	Phillips TM Large Pan Head Screw	SS304 Natural Finish M5×8	4	
	Standard Spring Washer	SS304 Natural Finish M5	4	
4	T66L (Single Antenna)	/	1	
5	Phillips TM Large Pan Head Screw	SS304 Natural Finish M4×8	13	
	Standard Spring Washer	SS304 Natural Finish M4	6	
6	Antenna Feeder Lightning Protector	SS304 Natural Finish	1	
7	UPS Lightning Protector Bracket	SS304 Natural Finish	2	
8	UPS Junction Box A	PVC Grey-White 40×30×300 mm	1	
9	UPS Junction Box B	PVC Grey-White 40×30×110 mm	1	
10	UPS Battery (Including Charger)	/	1	
11	UPS Battery Bracket	White Powder-Coated Metal	1	
12	Internal Phillips Hex Head Locking Screw	SS304 Natural Finish M6×8	8	
13	Solar Charge Controller:	RD1224-H10	1	
14	Phillips Pan Head Screw with Washer	Carbon Steel, Silver, Nickel-Plated M3×8	5	

III. Enclosure Accessories List

NO	Full Material Name	Specification	Unit	Image
15	Terminal Block Partition Plate	UK-2.5B Grey	2	
16	Terminal Block (Orange-Red)	UK-2.5B Nylon Orange	4	
	Terminal Block (Gray)	UK-2.5B Nylon Grey	1	
	Terminal Block (Blue)	UK-2.5B Nylon Blue	4	
17	Marker Strip (Numbered)	UK Series White, 10 positions/strip, 1 2 3 4	2	
18	Terminal Jumper Bar FBI-2-6	FBI-2-6 Silver, with Phillips screw	2	
19	Terminal End Clamp EUK	UK-2.5B Grey	3	
20	C45 U-Type DIN Rail	Length 144.5 mm	1	
21	Crimp Terminal E1508	Red 1.5 mm ²	12	
22	Adhesive Foam	EVA Black T1×W15×L150 mm	2	
23	Adhesive Foam	EVA Black T1×W15×L40 mm	2	
24	TNC Cable (Male to Female)	Length 0.3 m	1	
25	Corrugated Conduit	D25 PP Black, slit type, 1 m	1	
26	Ring Insulated Crimp Terminal	RV2-3 Black	1	
27	Wire Connector Cap	CE-5X Milky white	2	
29	Wire Marker Tube	White heat shrink tube, marking: + -	4	
30	4 m ² Stranded Wire	Yellow-green, 5 m	1	

III. Enclosure Accessories List



NO	Full Material Name	Specification	Unit	Image
30	2-pin LEMO connector power cable	0.5 meter	1	
31	Data cable	/	1	
32	TNC antenna cable	5 meters	1	

XFIX

IV. Pole Assembly Components List

NO	Full Material Name	Specification	Unit	Image
1	UPS lightning rod (top mounted)	Stainless steel, 1 m, D32 × H1000	1	
2	Hex locking nut	SS304 natural finish, M12	4	
	Hex bolt	SS304 natural finish, M12×100	4	
3	UPS mounting pole	Hot-dip galvanized, white, 1.5 m	1	
4	UPS enclosure	Galvanized, white, V4520-V1	1	
5	Lightning rod grounding wire	5 m, 16 mm ²	1	
6	UPS grounding rod	Galvanized, 0.5 m	2	
7	Ground cage / foundation cage	Steel, M16 nut and washer provided by customer	1	
8	Stranded electronic wire	4 mm ² yellow-green, 5 m, included in cabinet internal wiring	1	
9	U-bolt pipe clamp	SS304, hole Ø8.5 × 140 mm	2	
	T-bolt	SS304, M8×25	4	
	Hex locking nut (duplicate item)	SS304, M8	4	
	Washer	SUS304, M8×17×1.5	4	
10	Corrugated conduit	D25 PP black, slit type, 1 m	2	
11	Solar panel mounting bracket	Hot-dip galvanized, white, with fasteners (4 × M8×90)	1	
12	Solar panel	100 W solar panel, with screws (4 × M5×20)	1	
13	Antenna alignment pole joint	Two-end thread 5/8-11 UNC-2A, length 98 mm, Aluminum 6061 natural finish	1	

IV. Pole Assembly Components List





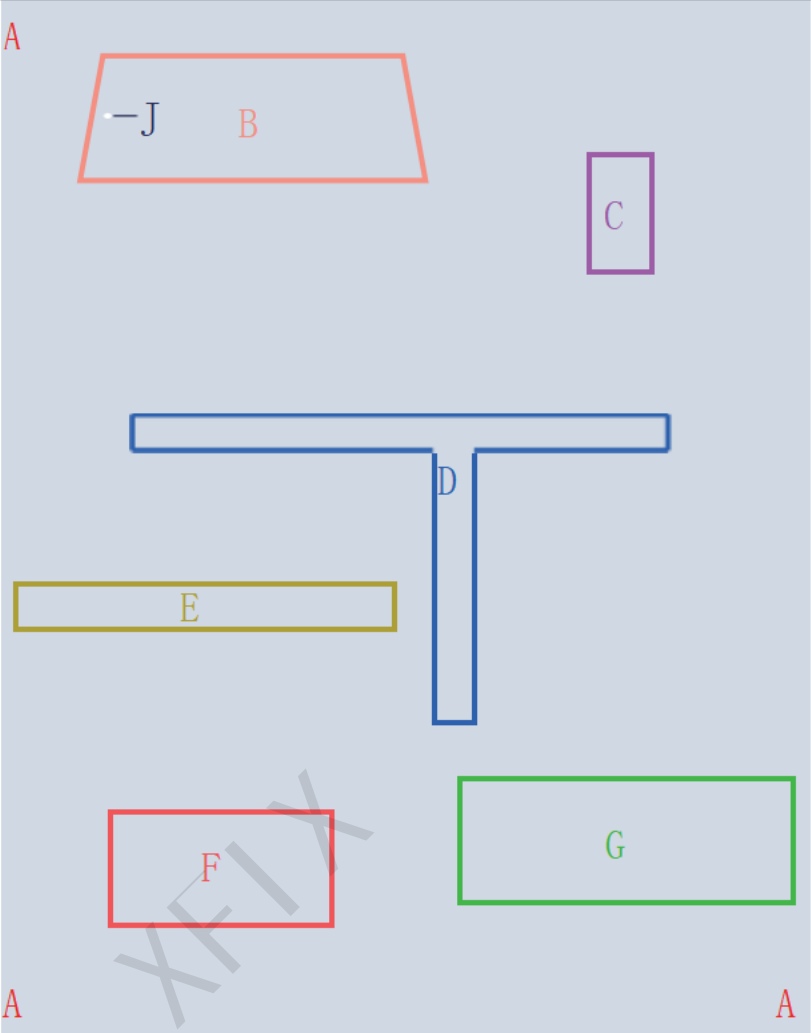

NO	Full Material Name	Specification	Unit	Image
14	TNC antenna cable	5 m, included in cabinet internal wiring	1	
15	Choke ring antenna	White	1	

XFIX

V. Enclosure Mounting Hole Layout and Corresponding Screw Specifications

<p>A – 4 × M6×8 Phillips hex flange lock screw, used to fix base plate</p>	 <p>The diagram shows a light blue rectangular enclosure with four red 'A' labels at the corners. Inside, there are several components: a red trapezoidal shape labeled 'B' with a '-J' symbol; a purple rectangular shape labeled 'C'; a blue T-shaped structure labeled 'D'; a yellow rectangular shape labeled 'E'; a red rectangular shape labeled 'F'; and a green rectangular shape labeled 'G'. A large, faint watermark 'XINXIN' is visible across the bottom half of the diagram.</p>
<p>B – 4 × M5×8 Phillips TM large pan head screw with washer, used to fix T66L main unit</p>	
<p>C – 4 × M4×8 Phillips TM large pan head screw with washer, used to fix antenna feeder lightning protector</p>	
<p>D – 7 × M4×8 Phillips TM large pan head screw with washer, used to fix junction box</p>	
<p>E – 2 × M4×8 Phillips TM large pan head screw with washer, used to fix terminal block DIN rail</p>	
<p>F – 4 × M3×8 Phillips pan head screw with washer, used to fix solar charge controller</p>	
<p>G – 4 × M6×8 Phillips hex flange lock screw, used to fix UPS power supply</p>	

VI. Installation Tools List

Installation Tools		
Specification	Corresponding Screws & Terminals	Image
Phillips screwdriver #0	M3×3, M3×8, M4×8 screws	
Phillips screwdriver #1	Terminal bridge screw	
Hex socket screwdriver Φ11	M5×8 screw	
Flathead screwdriver #0	M6×8 screw	
Wire ferrule crimping tool 0.25–2.5 mm ²	Terminal block screw	
Adjustable wrench 0–25 mm	Antenna feeder lightning arrester grounding wire	
Tubular terminal crimping tool 0.25–6 mm ²	Antenna connector, lightning rod hex screw	

VII. Enclosure Installation Diagram

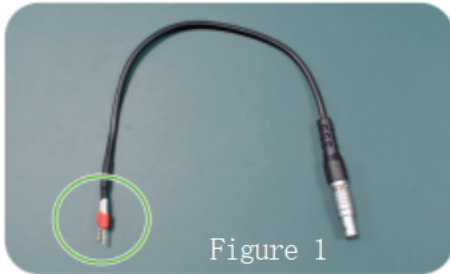

1. Modification of PW power cable As shown in Figure 1, sleeve wire markers + and - onto red (+) and black (-) wires, install red crimp terminal E1508, and crimp using a wire crimping tool.

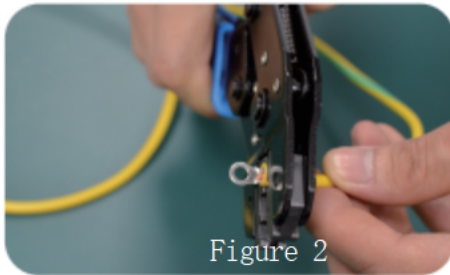

2. Modification of lightning arrester grounding wire As shown in Figure 2, remove the lug from the lightning arrester, cut 4 mm² yellow-green wire into 5 m, strip both ends by 8 mm, connect one end to original arrester lug and the other end to RV5.5-8 lug, and crimp using a wire crimping tool.

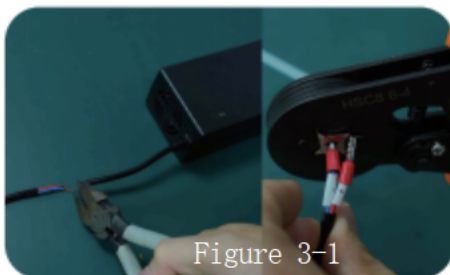

3. Modification of UPS charging cable As shown in Figure 3-1, cut the charging head of the UPS charger cable, sleeve wire markers red (+) and blue (-), install red crimp terminal E1508, and crimp using a wire crimping tool, as shown in Figure 3-2.

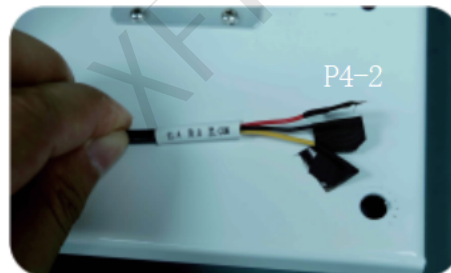
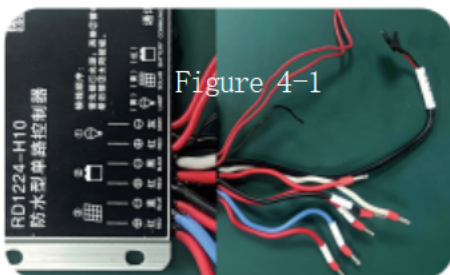

4. Modification of solar charge controller As shown in Figure 4-1, connect wire markers red (+), blue (-), black (-), gray (-) to the solar controller, install red crimp terminal E1508 and crimp using a wire crimping tool; as shown in Figure 4-2, wrap the three-core red/black/yellow wires with tape to prevent exposed ends.

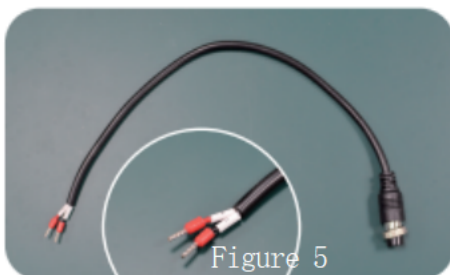

5. Modification of battery output cable As shown in Figure 5, sleeve wire markers + and - onto red (+) and black (-) wires, install red crimp terminal E1508, and crimp using a wire crimping tool.

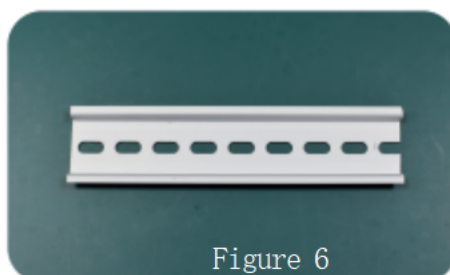

6. Cutting terminal block DIN rail C45U-type DIN rail, as shown in Figure 6, cut into 144.5 mm sections.

VII. Enclosure Installation Diagram

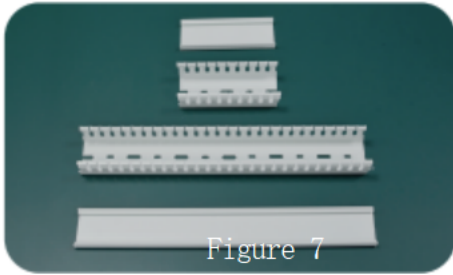

7. Cutting junction box UPS box A into 300mm pieces, UPS box B into 110mm pieces.

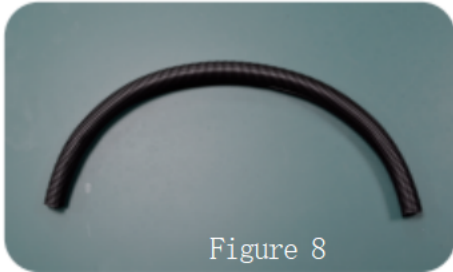

8. Corrugated conduit D25, cut into two 1-meter sections as shown in Figure 8.

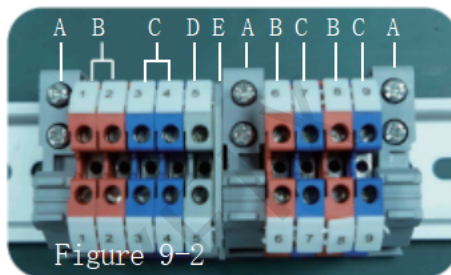
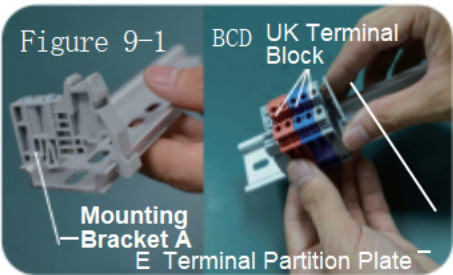

9. Install terminal blocks as shown in Figure 9-1 by assembling fixing parts, UK terminal blocks, and terminal separators. The terminal separators must be pressed onto the terminal blocks. A-3 pcs, B-4 pcs, C-4 pcs, D-1 pc, E-1 pc, as shown in Figure 9-2.

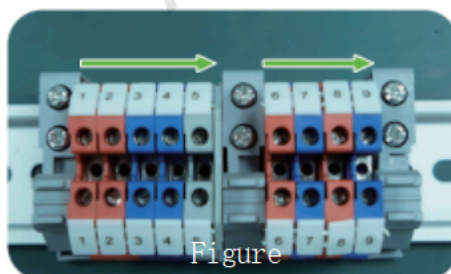
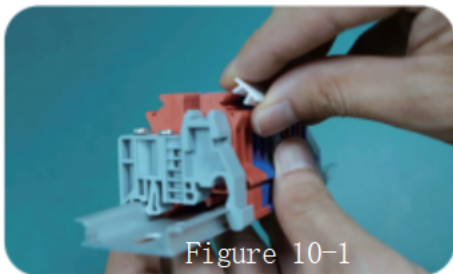

10. Marking labels are installed into the terminal block as shown in Figure 10-1, from left to right 123456789, as shown in Figure 10-2.

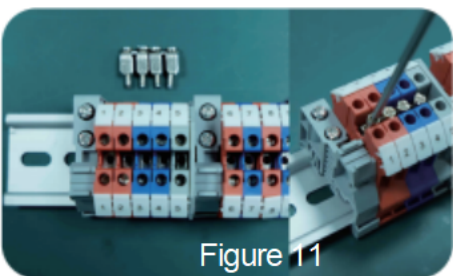

11. Insert two sets of FBI-2-6 connecting strips into terminal fixing holes 1-2 and 3-4 and tighten 4 fixing screws.

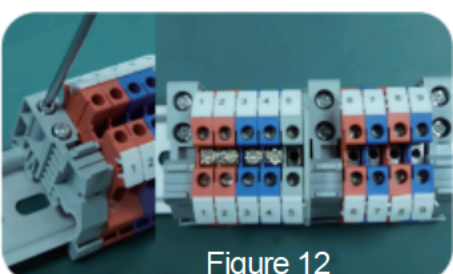

12. Tighten fixing parts as shown in Figure 12, hold all UK-2.5B terminal blocks by hand, and tighten 6 screws on EUK fixing parts using a screwdriver to ensure no gap between terminal blocks.

VII. Enclosure Installation Diagram



13. Remove base plate from enclosure as shown in Figure 13 by removing 4 Phillips hex flange lock screws and taking out the base plate.

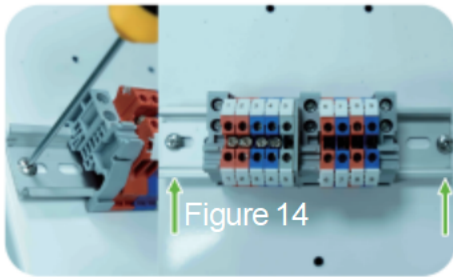

14. Fix terminal blocks to base plate as shown in Figure 14, refer to enclosure assembly drawing (Page P02), place terminal blocks at corresponding positions and tighten using 2 M4 Phillips screws with spring washers.

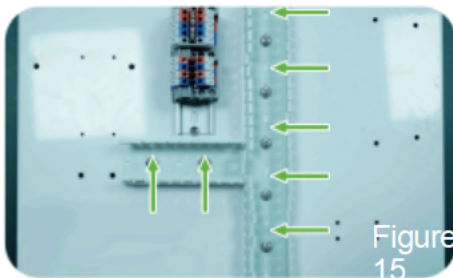

15. Install connecting box as shown in Figure 15, refer to enclosure assembly drawing (Page P02), and fix junction box A and B using M4 screws.

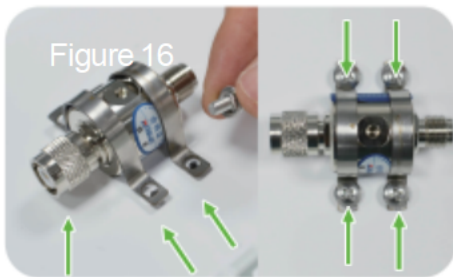

Figure 16

Nut End Lightning Arrester Bracket

16. Fix antenna feeder lightning arrester as shown in Figure 16, refer to enclosure assembly drawing (Page P02), place arrester on base plate with nut side facing T66L, install 2 brackets and tighten using 4 M4 Phillips screws with spring washers.



Figure 17-1



17. Fix T66L main unit as shown in Figure 17-1, refer to enclosure assembly drawing (Page P02), place T66L on base plate and secure using 4 M5×8 Phillips screws with spring washers; install M3×8 screw at grounding hole as shown in Figure 17-2.

VII. Enclosure Installation Diagram



Figure 18-1

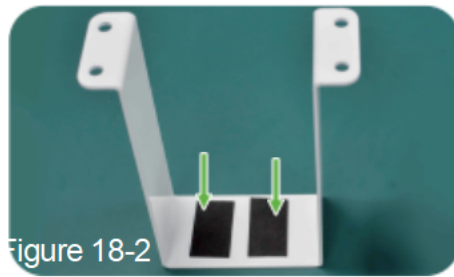

Figure 18-2



Figure 18-3

18. Fix UPS Refer to enclosure assembly drawing (Page P02). First apply two T1×W15×L150 foam strips on the right side of junction box B as shown in Figure 18-1; apply two T1×W15×L40 foam strips at the bottom of the UPS as shown in Figure 18-2; place the UPS onto the base plate with bracket and tighten using 4 M6 hex bolts as shown in Figure 18-3.

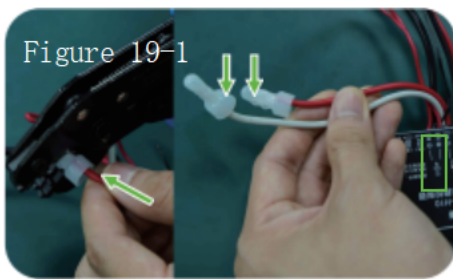

Figure 19-1



Figure 19-2

19. Solar charge controller power terminal wiring As shown in Figure 19-1, crimp ferrules onto the red/gray power wires of the solar charge controller using a crimping tool; Figure 19-2 shows the enlarged view of the controller.



Figure 20

20. Fix solar charge controller Refer to enclosure assembly drawing (Page P02). Place the solar charge controller at the corresponding position on the base plate and fix it using 4 M3×8 Phillips pan head screws with washers as shown in Figure 20.

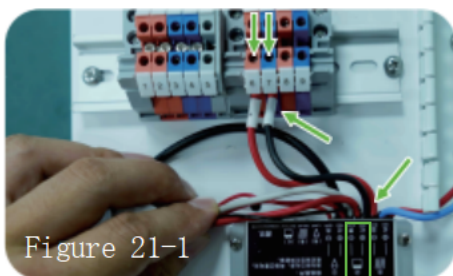

Figure 21-1

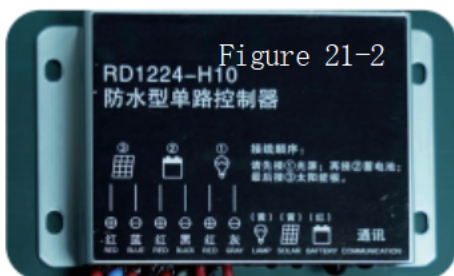
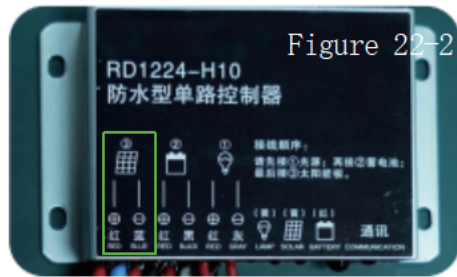
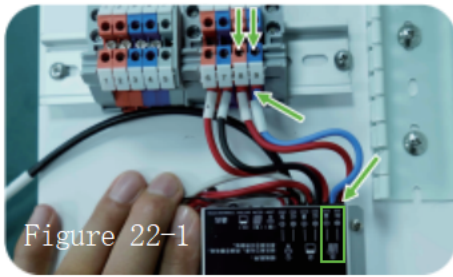

Figure 21-2

21. Solar charge controller battery terminal wiring As shown in Figure 21-1, connect the red/black battery wires of the solar charge controller to terminal block ports 6 (red) and 7 (black), and tighten terminal screws; Figure 21-2 shows the enlarged controller view.

VII. Enclosure Installation Diagram



22. Solar charge controller PV terminal wiring As shown in Figure 22-1, connect the red/blue PV wires of the solar charge controller to terminal block ports 8 (red) and 9 (blue), and tighten terminal screws; Figure 22-2 shows the enlarged controller view.

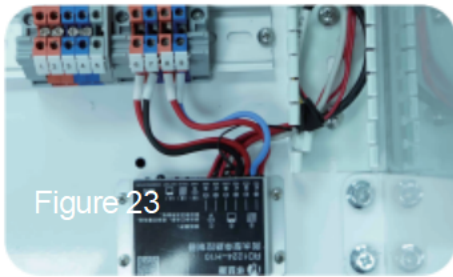

23. Solar charge controller cable management Route unused cables into junction box B as shown in Figure 23.

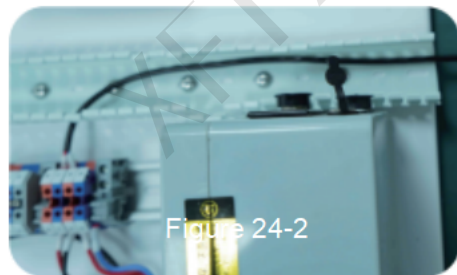

24. UPS charging cable wiring As shown in Figure 24-1, connect the red (+) and blue (-) UPS charging wires to terminal block ports 6 (red) and 7 (blue), and tighten terminal screws; route cables through junction box A as shown in Figure 24-2.

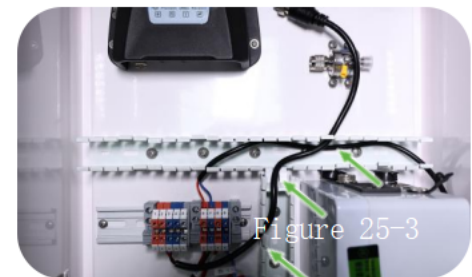
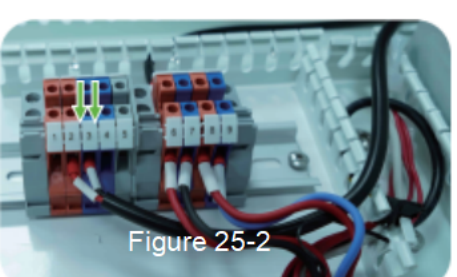

25. Output terminal wiring As shown in Figure 25-1, route battery output red (1) and black (-) wires through the lower part of the solar controller wiring; connect to terminal block ports 2 (red) and 3 (black), and tighten terminal screws as shown in Figure 25-2; route cables through junction boxes A and B as shown in Figure 25-3.

VII. Enclosure Installation Diagram

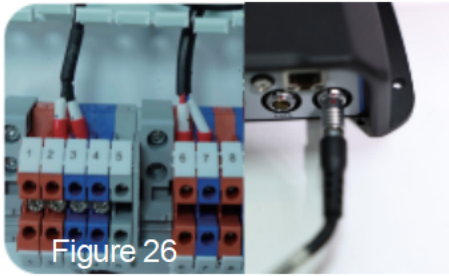

26. 2-pin LEMO power cable wiring As shown in Figure 26-1, connect the 2-pin LEMO power cable to the upper terminals of terminal block 2 (+) and 3 (-) and tighten; insert the LEMO connector into the T66L “PW” port aligning red dot to red dot as shown;

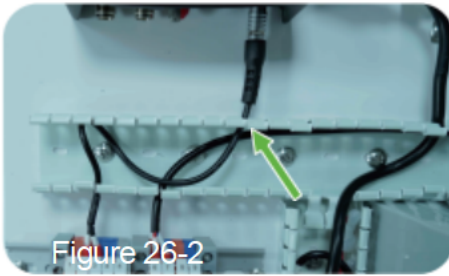

route cables through junction box A as shown in Figure 26-2.



27. 0.3 m TNC cable connection As shown in Figure 27-1, connect one end to the T66L “GNSS” port and the other end to the lightning arrester nut terminal as shown in Figure 27-2, then route through junction box A as shown in Figure 27-3.



28. Data cable wiring As shown in Figure 28-1, insert the data cable LEMO connector aligning red dot to red dot into the T66L “DATA” port, and route cables as shown in Figure 28-2.



29. Install base plate As shown in Figure 29-1, insert the assembled base plate into the enclosure at an angle (pre-insert the bottom-right screw into the hole for easier installation), then tighten 4 M6 hex flange lock screws as shown in Figure 29-2.

VII. Enclosure Installation Diagram

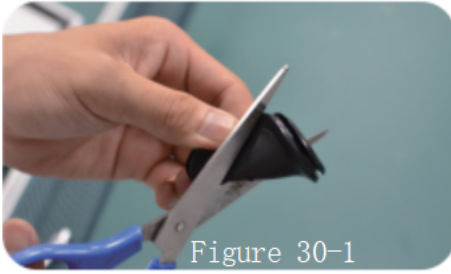

Figure 30-1

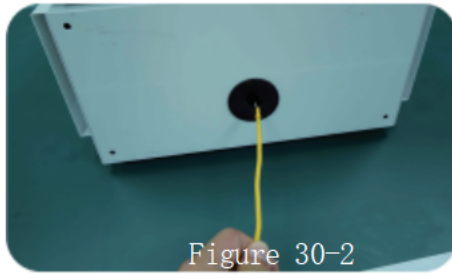

Figure 30-2



Figure 30-3

30. Install enclosure rubber grommet and route lightning arrester grounding wire As shown in Figure 30-1, cut the rubber grommet; route the lightning arrester grounding wire through the grommet into the enclosure as shown in Figure 30-2; place wire into corrugated conduit and insert conduit into grommet as shown in Figure 30-3.

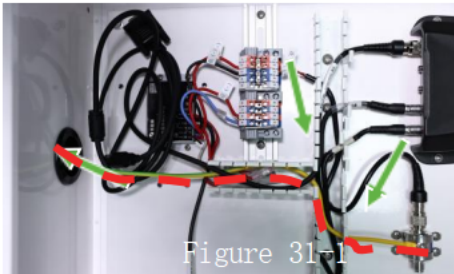
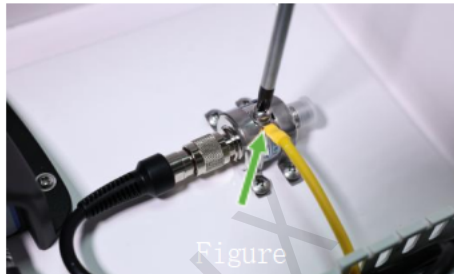

Figure 31-1



Figure

31. Lightning arrester grounding wire connection As shown in Figure 31-1, route grounding wire through enclosure hole, through junction box B and out via junction box A, place lug at top screw hole of lightning arrester and tighten as shown in Figure 31-2.



32. Install junction box covers As shown in Figure 32, install covers for junction boxes A and B.



Figure 33

33. UPS input and output wiring As shown in Figure 33, insert the power plug into the UPS input terminal, and insert the aviation connector into output 2.

VIII. Pole Installation Diagram

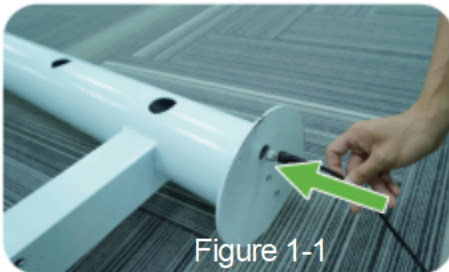
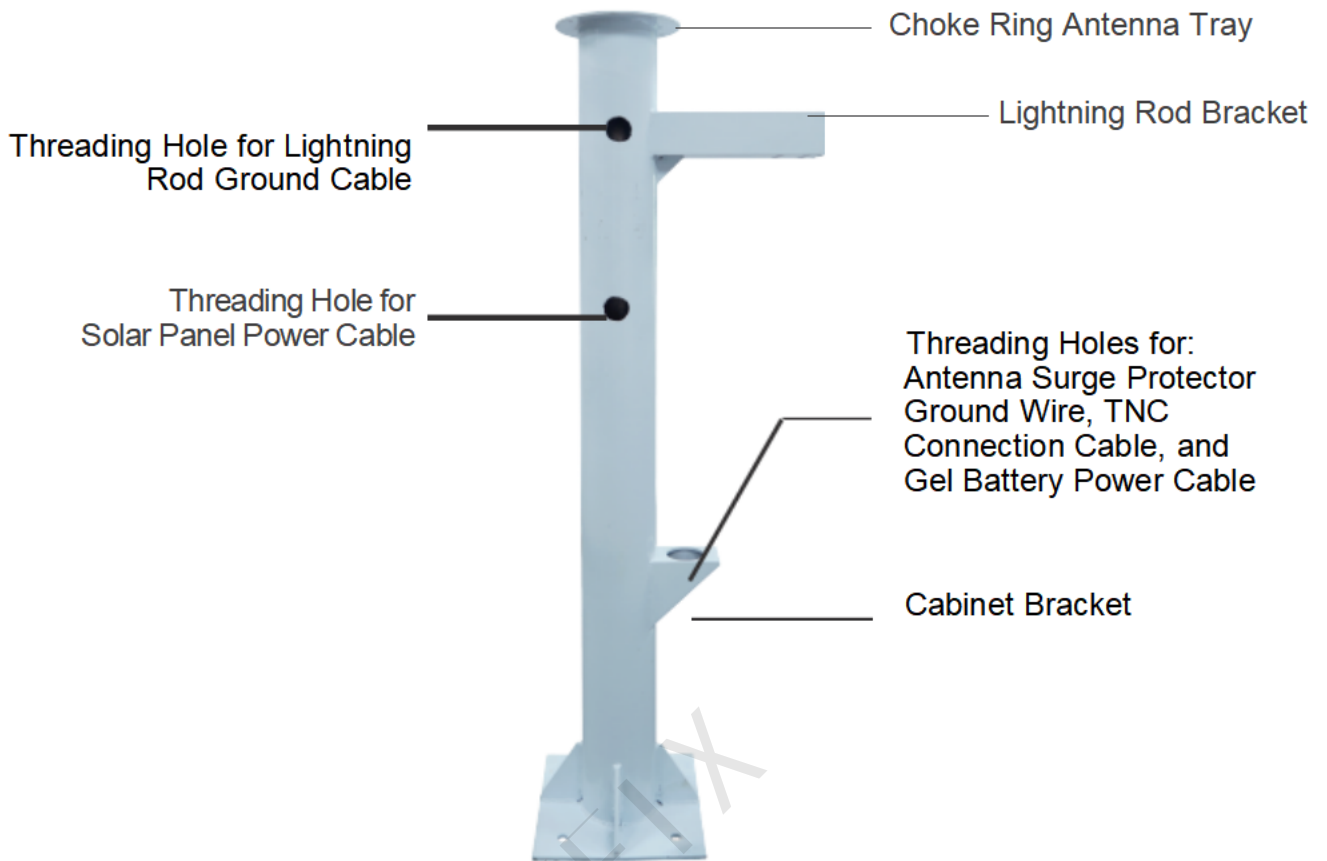

1. Route TNC cable As shown in Figure 1-1, route the TNC cable downward from the top choke ring antenna tray hole of the pole (it is easier when the pole is vertical), and pass it out from the enclosure bracket hole as shown in Figure 2.

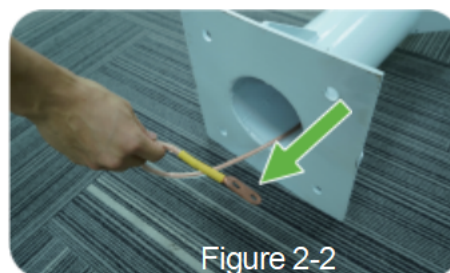
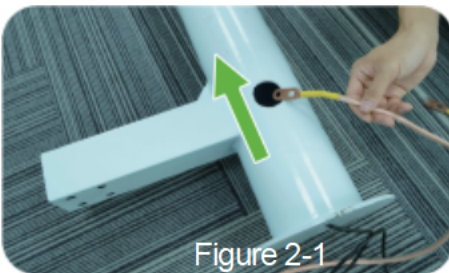

2. Route lightning rod grounding wire As shown in Figure 2-1, route the lightning rod grounding wire downward through the grounding wire hole (easier when pole is vertical), then pass it out from the bottom of the pole as shown in Figure 2-2.

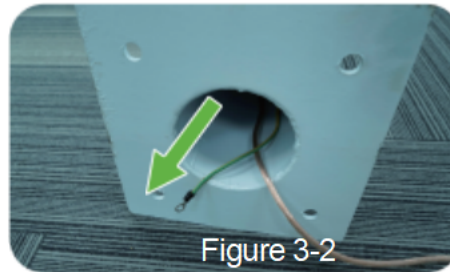

3. Route antenna feeder lightning arrester grounding wire As shown in Figure 3-1, route the grounding wire downward through the enclosure bracket hole and out from the bottom pole hole as shown in Figure 3-2.

VIII. Pole Installation Diagram

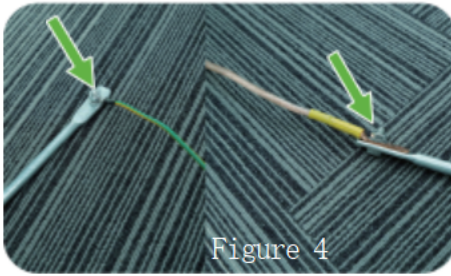

4. Ground rod connection As shown in Figure 4, fix the antenna feeder grounding wire and lightning rod grounding wire onto two ground rods using the screws provided with the ground rods.

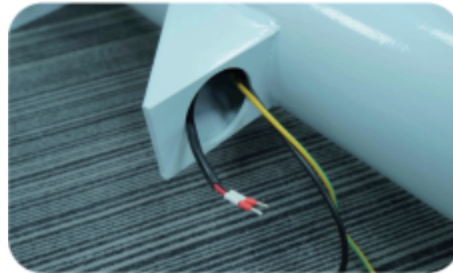
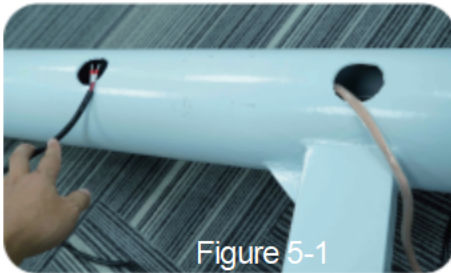

5-2。 5. Route solar panel power cable As shown in Figure 5-1, route the solar panel power cable downward through the cable hole and out from the enclosure bracket hole as shown in Figure 5-2.

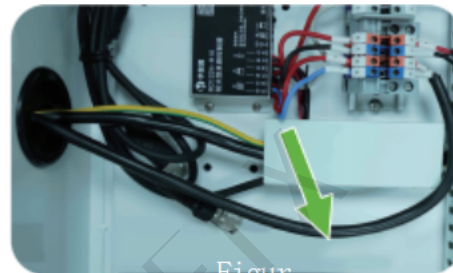
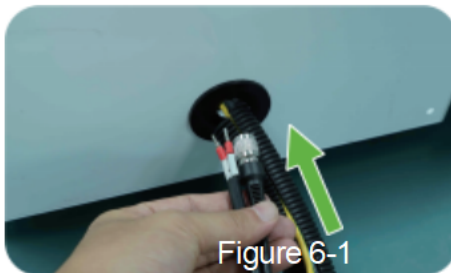

6. Connect solar panel power cable As shown in Figure 6-1, route the TNC cable and solar panel power cable into the enclosure through the bottom hole as shown in Figure 6-2; connect red (+) and black (-) wires to terminal block ports 8 (red) and 9 (black) and tighten screws as shown in Figure 6-3.

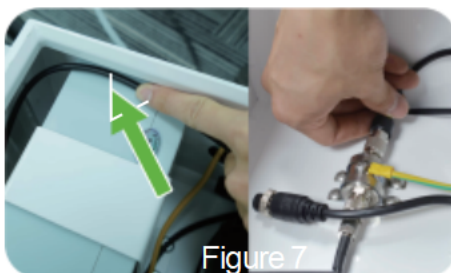

7. Connect TNC cable As shown in Figure 7, route the TNC cable through the gap between UPS battery and enclosure bottom, then connect it to the lightning arrester.

VIII. Pole Installation Diagram

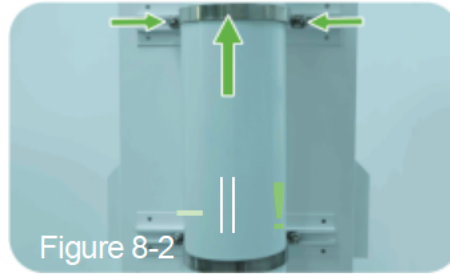

8. Fix enclosure As shown in Figure 8-1, insert 4 M8 T-bolts with washers into enclosure slots; align clamp with the 4 T-bolts as shown in Figure 8-2 and secure enclosure to pole using M8 lock nuts. .



9. Fix lightning rod As shown in Figure 9, fix the lightning rod onto the pole arm using 4 M12 screws.



10. Fix lightning rod grounding wire As shown in Figure 10, use two original screws of the lightning rod to secure the copper lug to the grounding terminal, then cover the flexible copper wire with corrugated conduit. .

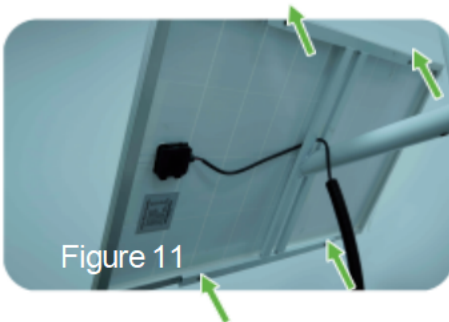

11. Fix solar panel to bracket As shown in Figure 11, fix the solar panel to the bracket using 4 screws provided with the panel.



12. Fix solar panel bracket As shown in Figure 12, fix the solar panel bracket to the pole using 4 screws provided with the bracket.



13. Route solar panel cable into corrugated conduit As shown in Figure 13, place exposed solar panel cable into corrugated conduit and insert into pole.

VIII. Pole Installation Diagram

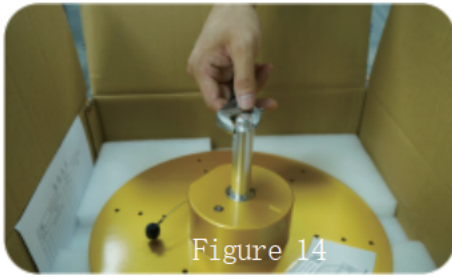

Figure 14

14. Install adapter rod to antenna As shown in Figure 14, screw the adapter rod clockwise into the antenna base and tighten with a wrench.

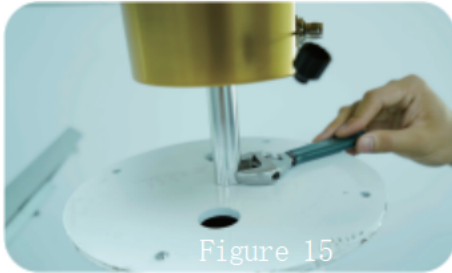

Figure 15

15. Fix antenna to pole As shown in Figure 15, align adapter rod with pole threaded hole, install antenna clockwise onto pole and tighten with wrench.

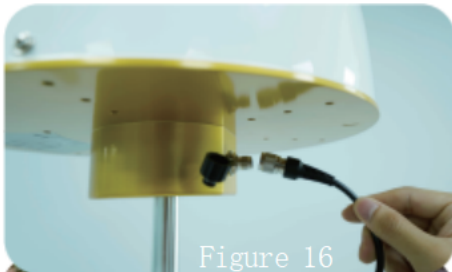

Figure 16

15. Fix antenna to pole As shown in Figure 15, align adapter rod with pole threaded hole, install antenna clockwise onto pole and tighten with wrench.16. Connect TNC cable As shown in Figure 16, insert male



Figure 17

17. Fix pole Stand the pole upright and align with foundation cage bolts, then secure using provided nuts as shown in Figure 17. (Seal cable holes on pole with foam glue to prevent foreign objects entering.)